

MUL-331 Sealer for POLYESTER

Operation Manual

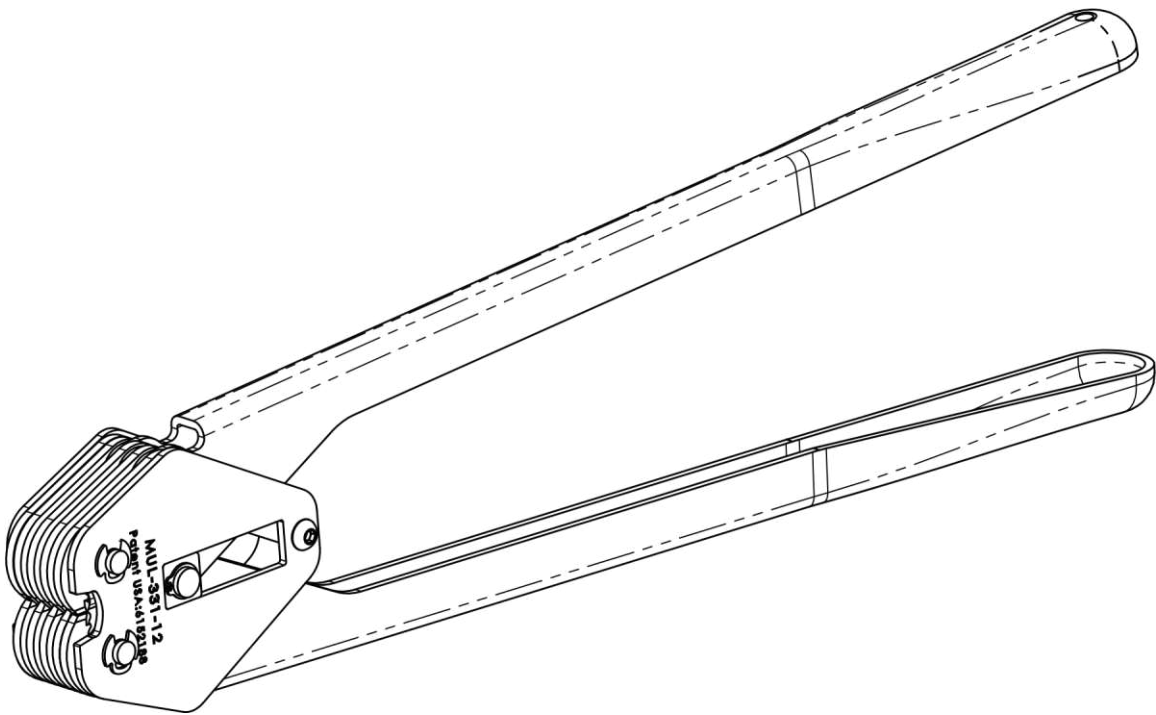

Strap Type	Polyester (PET)
Strap Width	1/2" (13 mm)
Strap Thickness	Up to 0.040" (1 mm)
Joint Type	Seal
Weight	4.5 lbs (2 kg)
Handle Length	17.5"

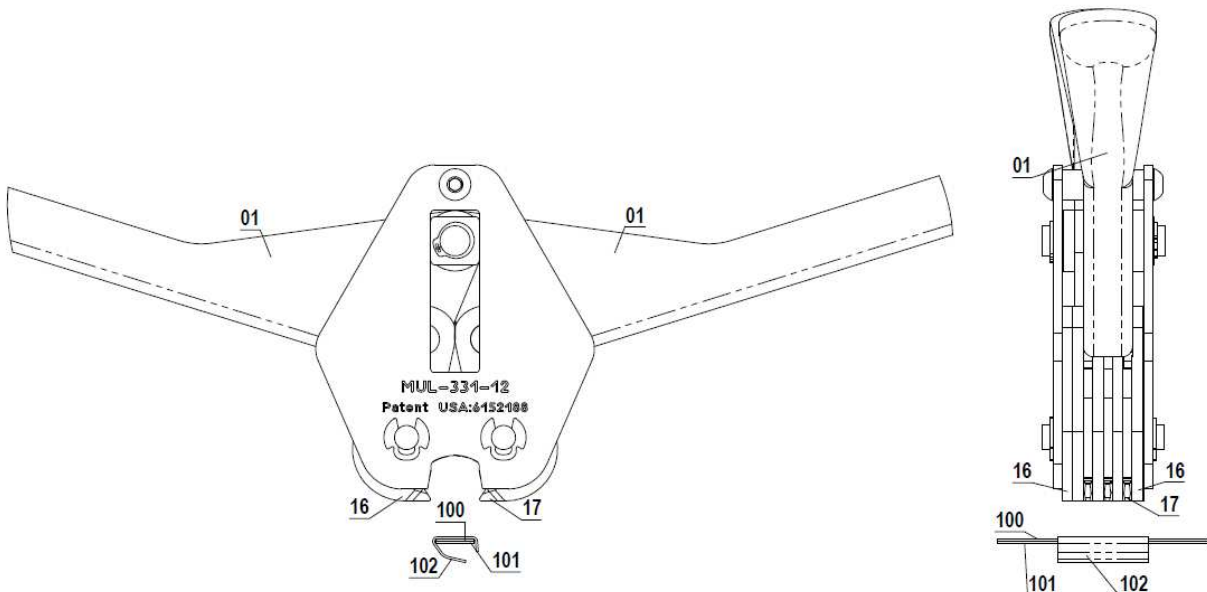

Fig. 1 – Starting Position

1. Place the **Outer Jaws 16** and **Inner Jaws 17** of the tool across the middle of the **Seal 102** as shown on Fig. 2.

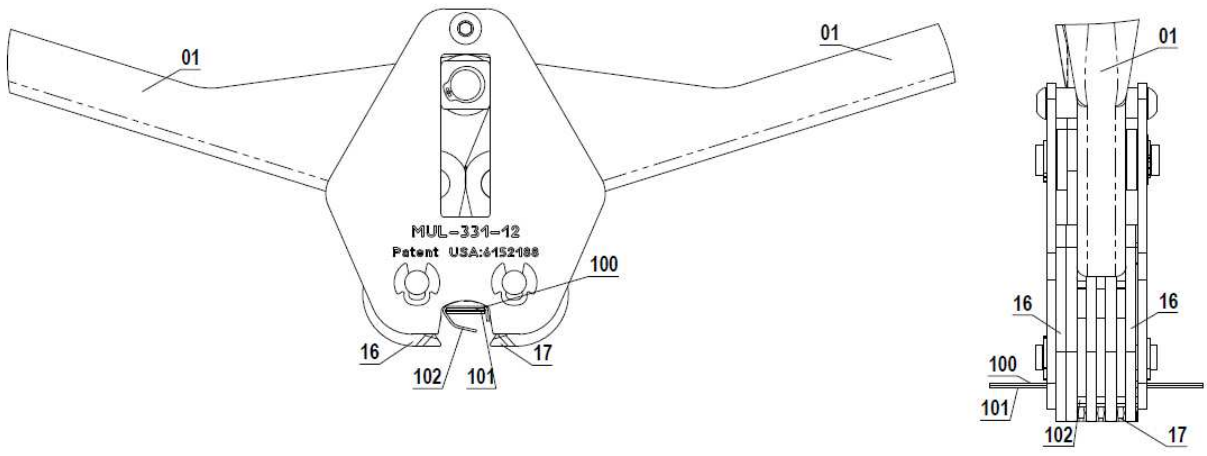

Fig. 2

2. Keeping the sealer in vertical position, press the **Handles 01** together till they cannot be squeezed no further as shown on Fig. 3.

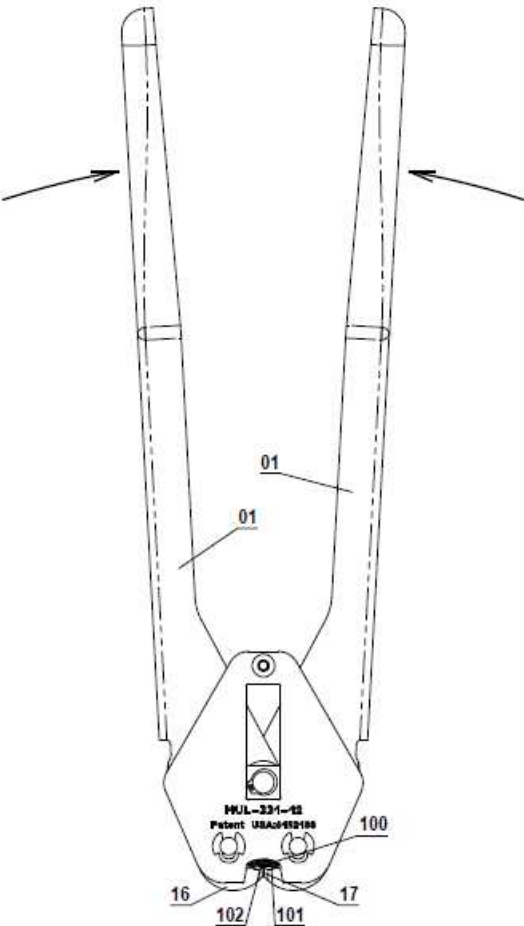

Fig. 3

3. Unclench the **Handles 01** and remove the sealer from the **seal 102** as shown on Fig. 4. Operation cycle is now complete.

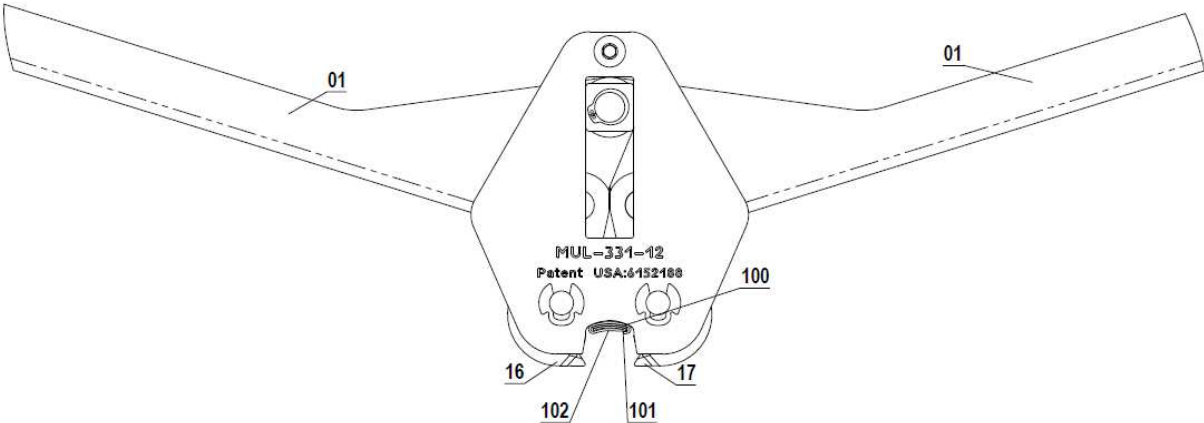

Fig. 4