

Adjustment instructions for MUL-350/351

1. Adjustment for seal height.

Proper slot for a seal is achieved when the seal can be inserted in the slot with ease, but sits tightly in the slot. **NOTE:** if the seal is loose in the slot, the joint might not close properly.

- 1.1. Hold 350-63 SET SCREW 4x20 in place by using T-Key 2mm and loosen 350-60 NUT M4 using Wrench 7mm (Fig. 1a).

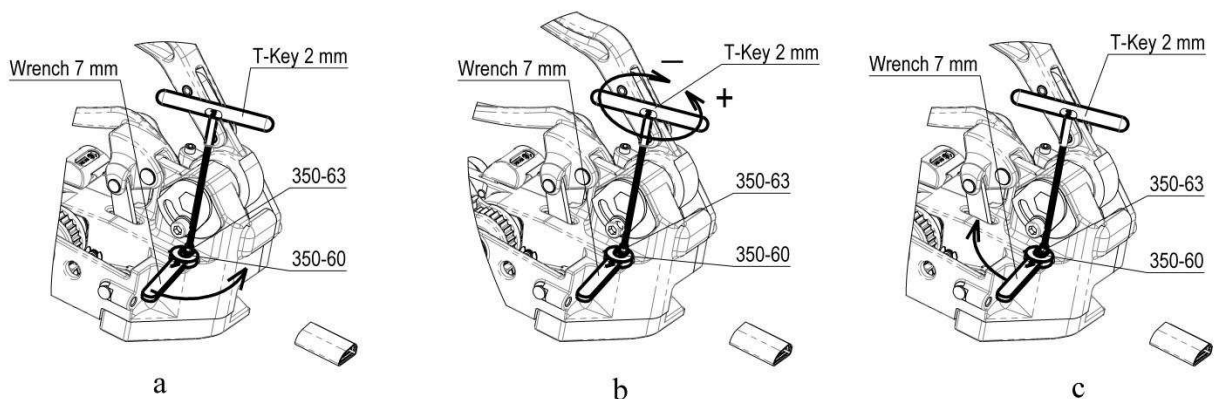

Fig. 1

- 1.2 Hold 350-60 NUT M4 in place and make an adjustment by turning T-Key 2mm (Fig. 1b).

- Clockwise rotation will lower the slot for a seal.
- Counter-clockwise rotation will raise the slot for a seal.

- 1.3 Once required height is achieved, hold T-Key 2mm in place and tighten 350-60 NUT M4 (Fig. 1c).

2. Adjustment for strap thickness.

Factory setting for strap thickness is 0.035" (0.9mm). MUL-350/351 can be adjusted to work on strap up to 0.040" (1mm).

- 2.1. Using T-Key 5mm loosen 350-67 SCREW M6x12 (Fig. 2a).

- 2.2. Turn 350-57 ADJUSTMENT PLATE to adjust for required strap thickness (Fig. 2b). 15° turn is roughly equivalent of 0.004" (0.1mm) adjustment in strap thickness.

- Clockwise rotation will adjust for thinner strap.
- Counter-clockwise rotation will adjust for thicker strap.

2.3 Hold 350-57 ADJUSTMENT PLATE in place and tighten 350-67 SCREW M6x12 (Fig. 2c).

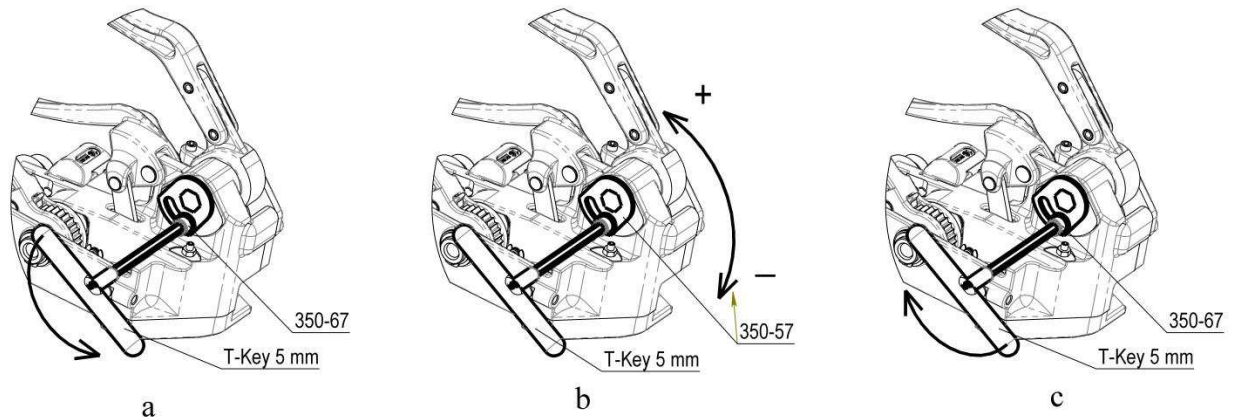

Fig. 2

3. 350-50 GRIPPER FOOT adjustment.

Proper position of the 350-50 GRIPPER FOOT is roughly 0.004" (0.1mm) above 350-10 GRIPPER PAD. The gap should be enough to insert a piece of paper and remove it without damaging the paper. (Fig. 3)

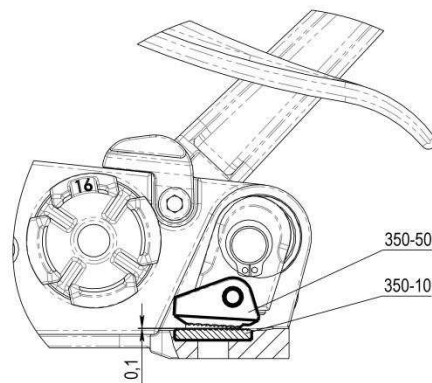

Fig. 3

3.1. Move 350-11 TENSION HANDLE to a position shown on Fig. 4a.

3.2. Raise 350-02 HANDLE against the stop (Fig. 4a).

3.3. Hold 350-69 SET SCREW M5x30 with T-Key 2.5mm and loosen 350-68 NUT M5 (Fig. 4a).

3.4. Turn T-Key 2.5mm to adjust 350-50 GRIPPER FOOT position (Fig. 4b).

- Clockwise rotation will raise the gripper foot.
- Counter-clockwise rotation will lower the gripper foot.

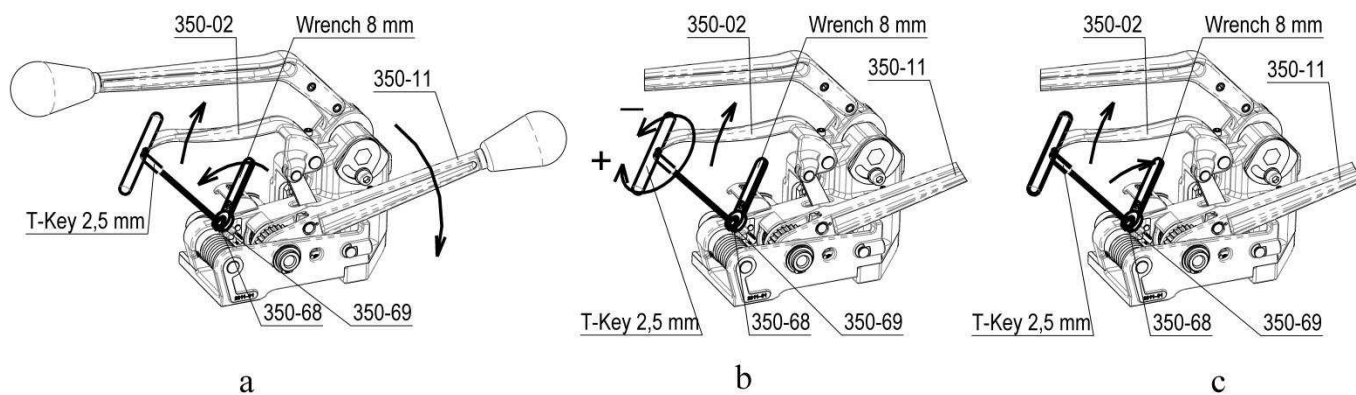

Fig. 4

3.5. Hold 350-69 SET SCREW M5x30 in place and tighten 350-68 NUT M5 (Fig. 4c).