

MUL-325 Tensioner for POLYESTER

Operation Manual

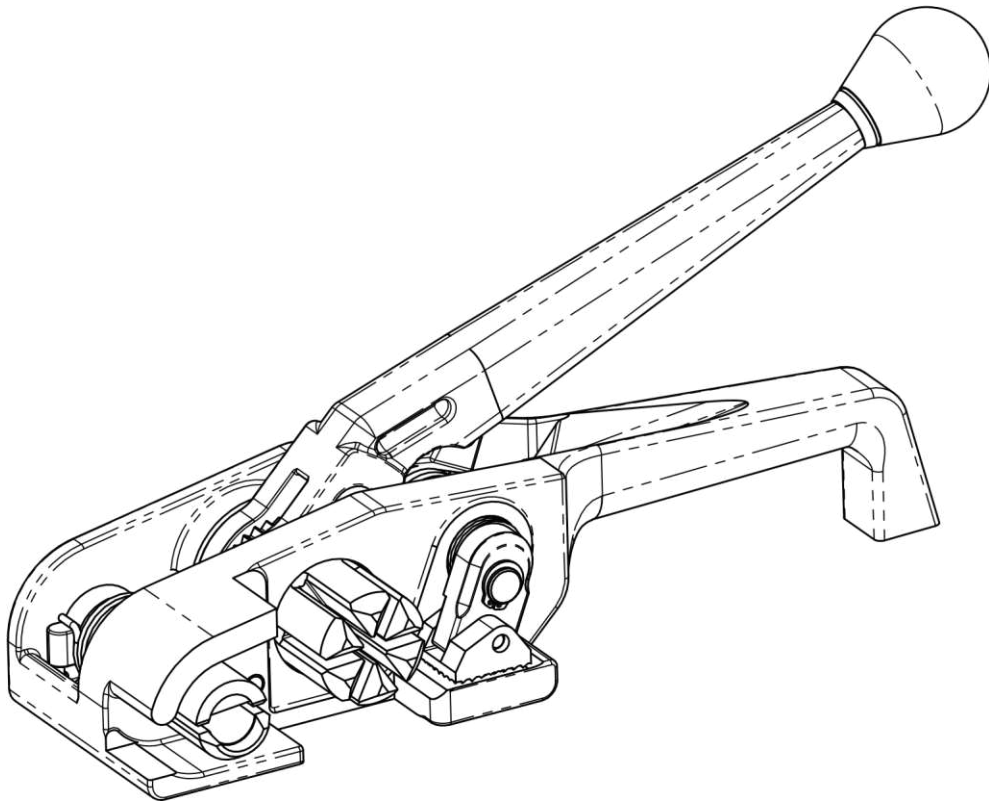

Strap Type	Composite/Woven Cord
Strap Width	Up to 3/4" (19 mm)
Strap Thickness	All existing straps
Joint Type	Buckle
Weight	3.6 lbs (1.6 kg)
Footprint	L: 4.75"; W: 2.75"
Handle Length	9"

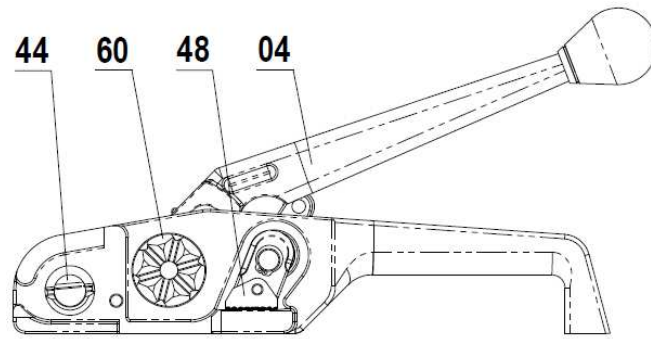

Fig. 1 – Starting Position

1. Wrap the strap around the package. Load one end of the strap **103** into the **Buckle 102**. Load the other **End 100** into **Buckle 102**. Manually, take out the excess strap by pulling on **End 100**. Place the **MUL-325** approximately 10" from the **Buckle 102** as shown on Fig. 2.

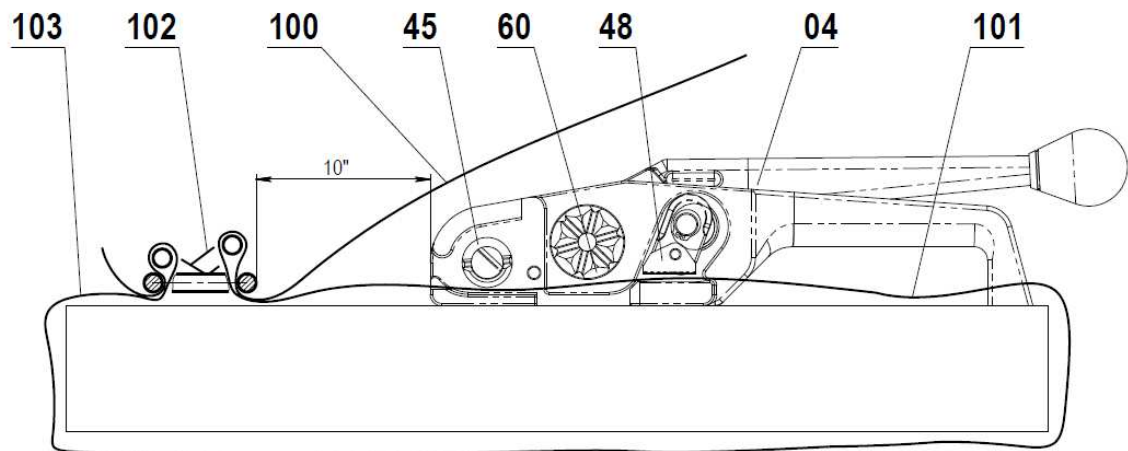

Fig. 2

2. Raise **Gripper Foot 48** by pressing down on **Tension Handle 04**. Load **Bottom Strap 101** under **Cutter Housing 45**, under **Gripper Foot 48** end release **Tension Handle 04**. Load **Upper Strap 100** through **Cutter Housing 45** through **Windlass 60** as shown on Fig. 3.

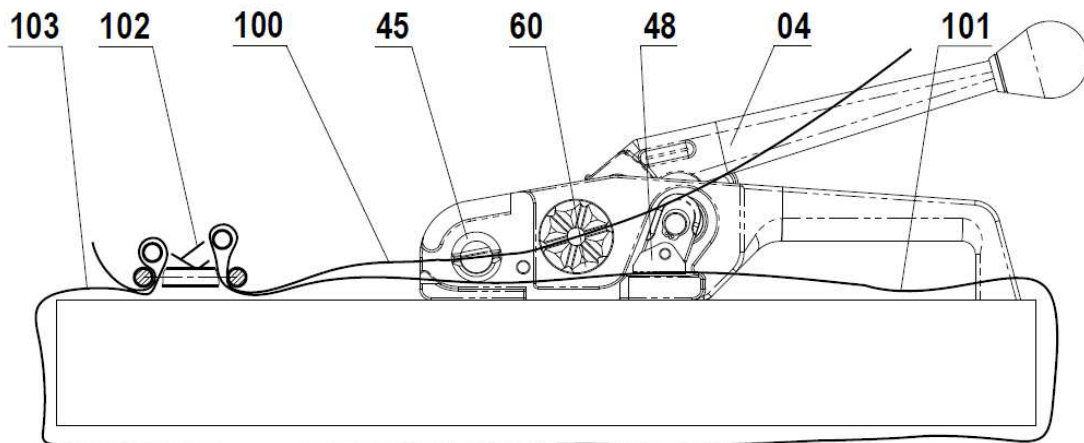

Fig. 3

3. Apply tension by ratcheting **Tension Handle 04** as shown on Fig. 4.

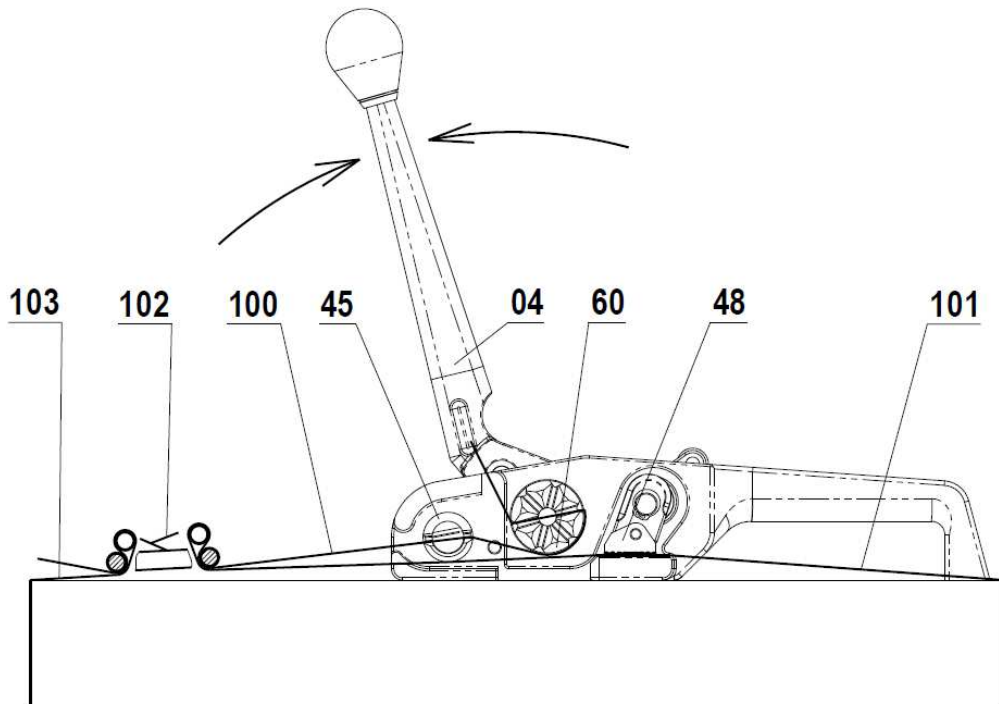

Fig. 4

4. Once satisfactory tension is achieved the strap is ready to be cut. Push down on the **Tension Handle 04** until the strap is cut and slide the tensioner to the right to release the strap from under the **Gripper Foot 48** as shown on Fig. 5. The operation cycle is now complete.

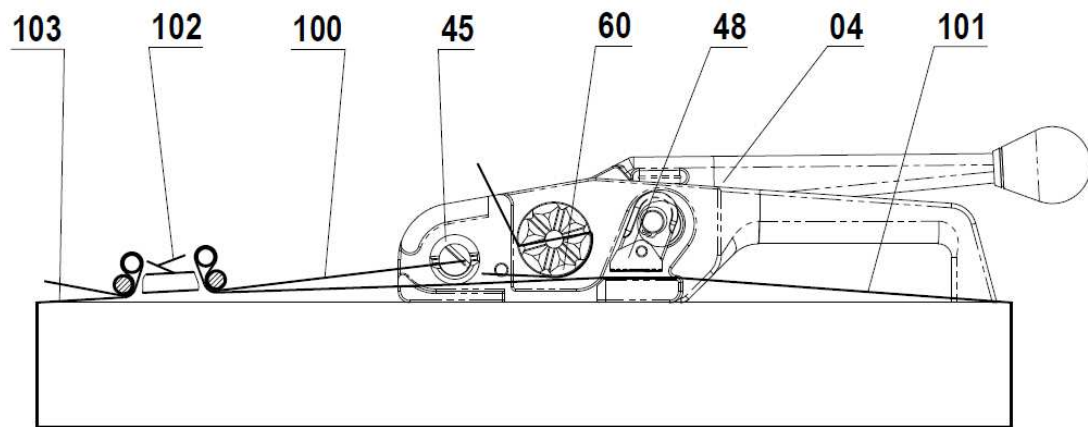

Fig. 5