

# MUL-350/MUL-351 Combination Tool for POLYESTER

## Operation Manual

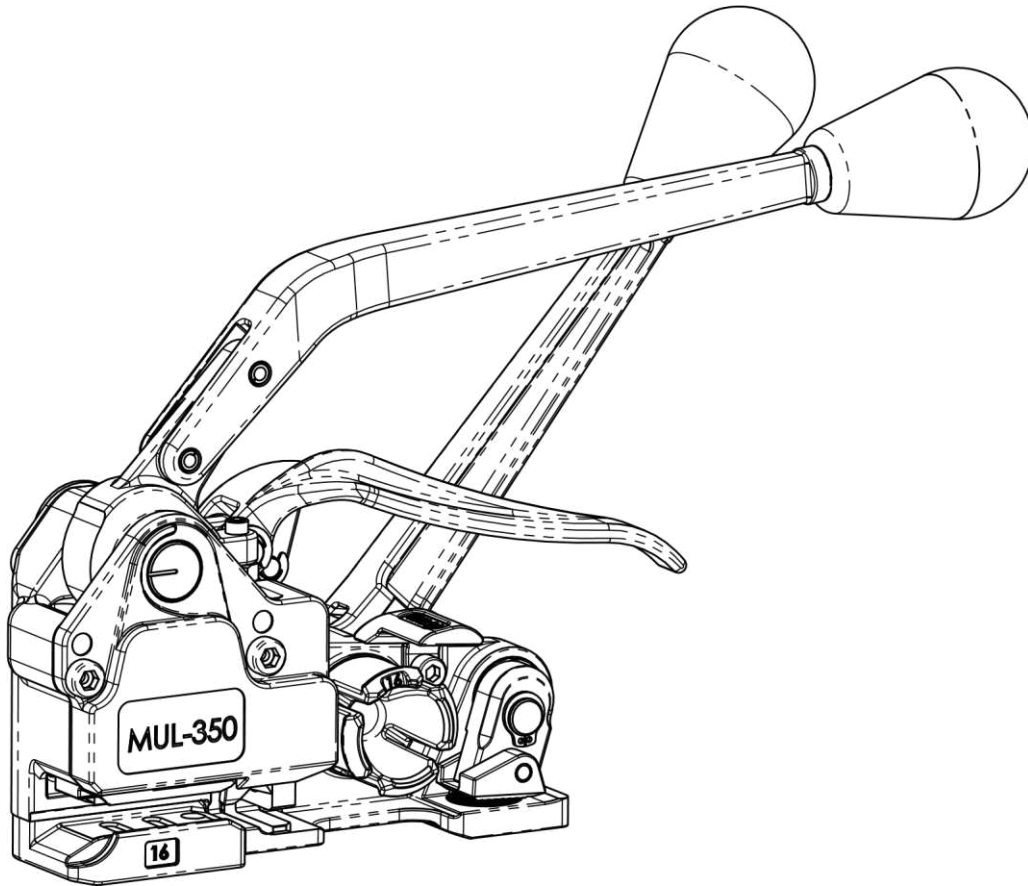

Strap Type	Polyester (PET)
Strap Width	MUL-350 5/8" (16 mm), MUL-351 1/2" (13 mm)
Strap Thickness	Up to 0.040" (1 mm)
Joint Type	Seal
Weight	8.3 lbs (3.8 kg)
Footprint	L: 5.75"; W: 2.85"

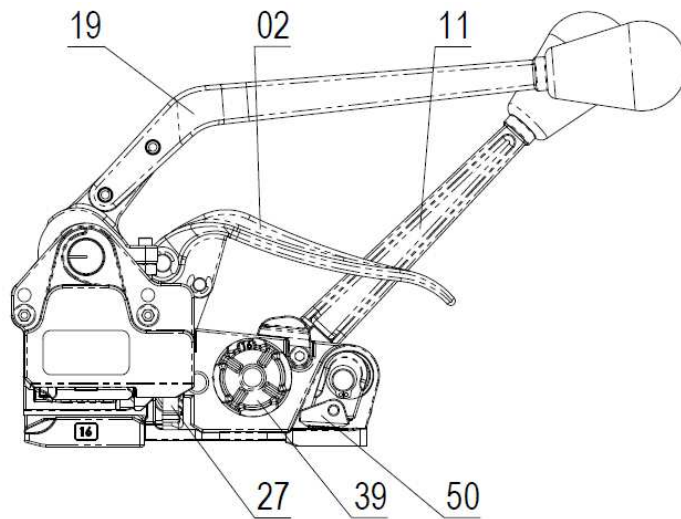

**Fig. 1 – Starting position**

1. Load a seal as shown on Fig. 2. For MUL-350 use open serrated seals for 5/8" (16mm) strap and for MUL-351 use open serrated seals for 1/2" (12mm) strap.

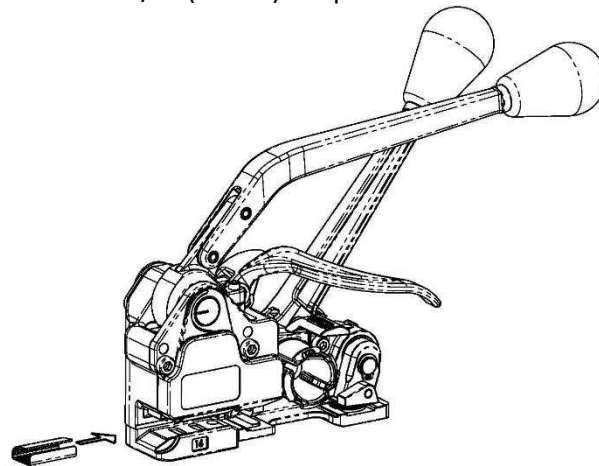

**Fig. 2**

2. Pull up on **Handle 02** to raise **Gripper Foot 50**. Load bottom strap **101** inside the seal **102**, under **Windlass 39** and under **Gripper Foot 50** as shown on Fig. 3.

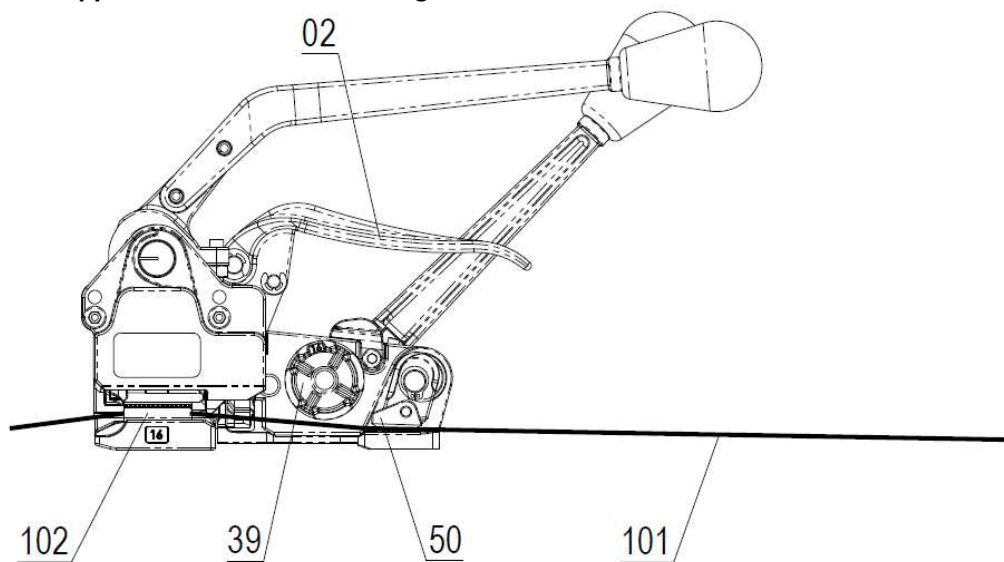

**Fig. 3**

3. Release **Handle 02** and load upper strap **100** inside the seal **102**, through the cutter and through **Windlass 39** as shown on Fig. 4.

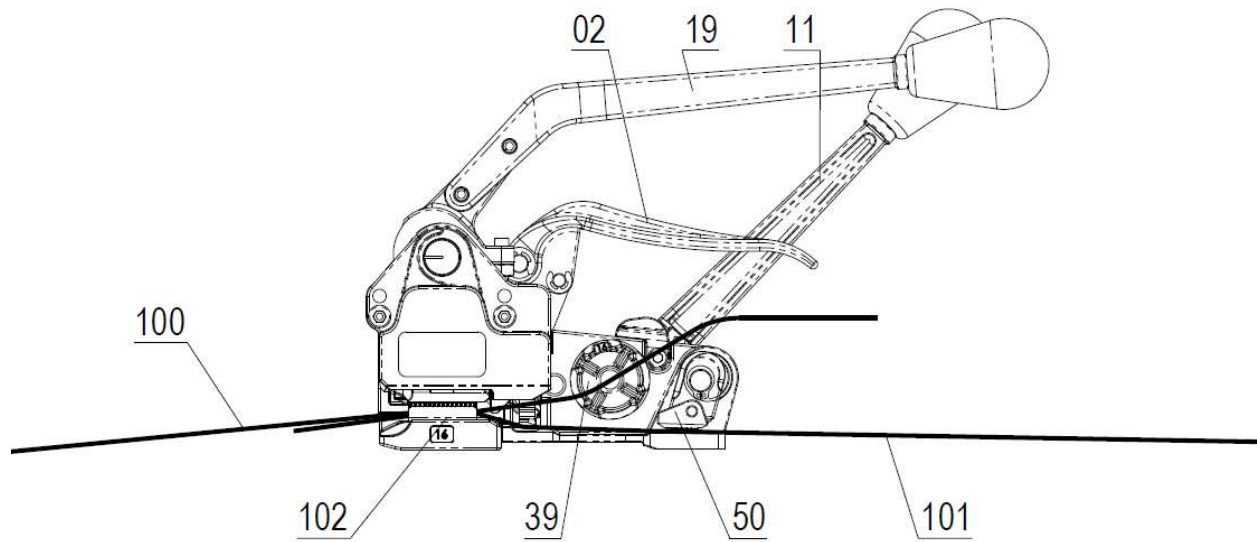

Fig. 4

4. Apply tension by ratcheting **Tension Handle 11** as shown on Fig. 5.

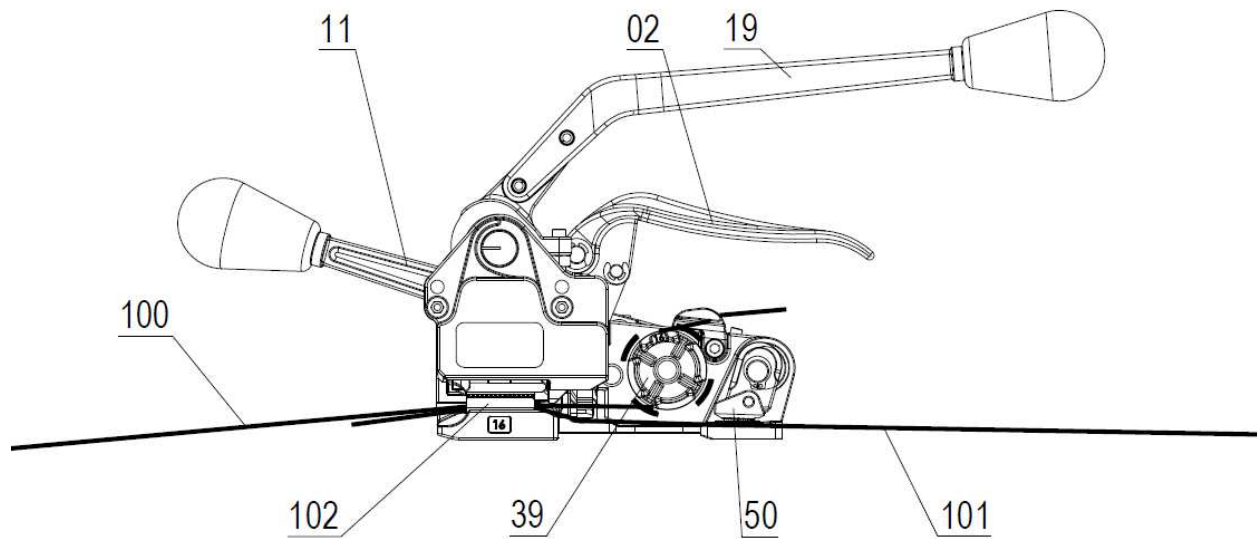

Fig. 5

5. Once satisfactory tension is achieved return **Tension Handle 11** back and push **Sealing Handle 19** forward (as shown on Fig. 6) to close the seal.

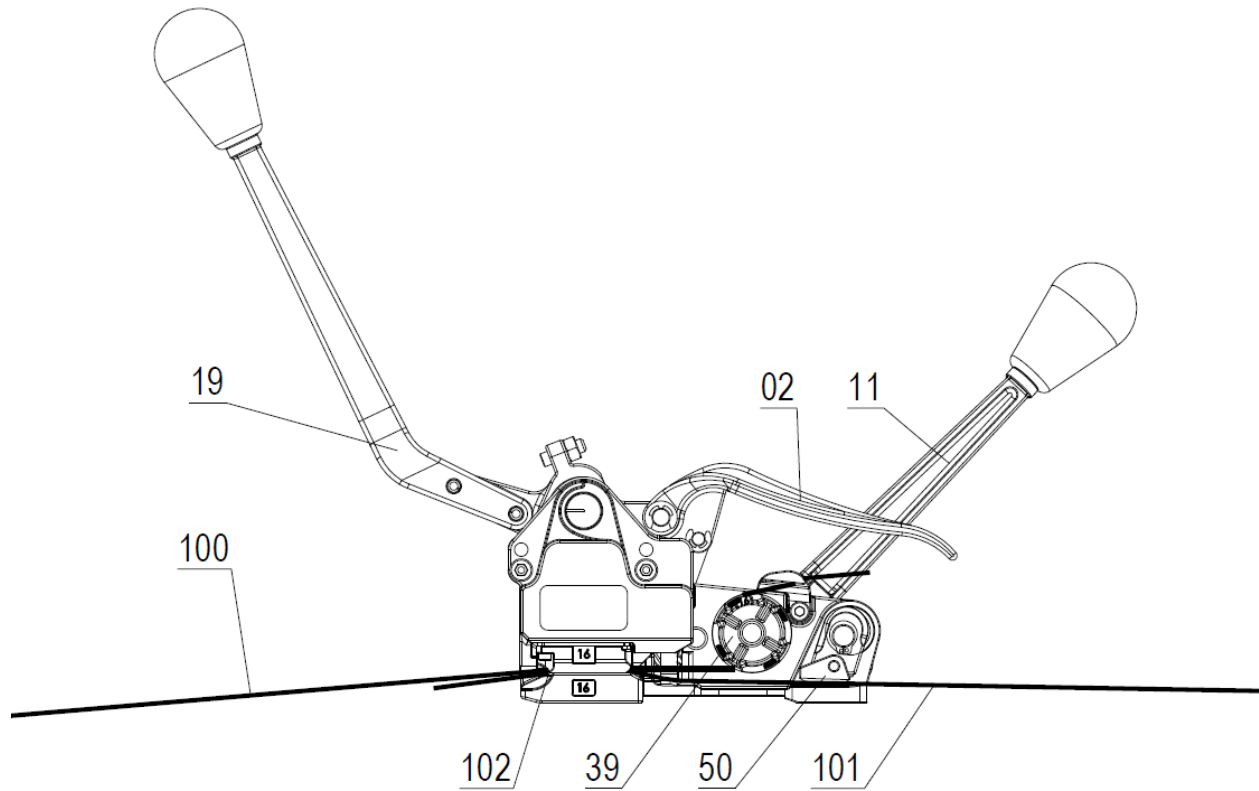

Fig. 6

6. Return **Sealing Handle 19** back and pull up **Handle 02** to cut the strap. The operation cycle is now complete.

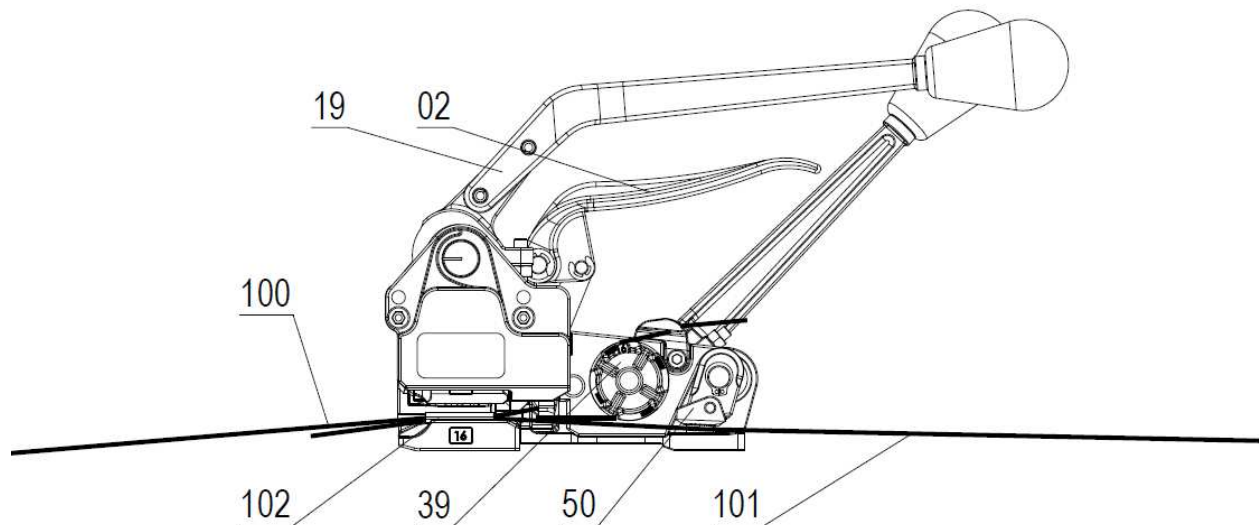

Fig. 7