

MUL-430 Sealer for STEEL

Operation Manual

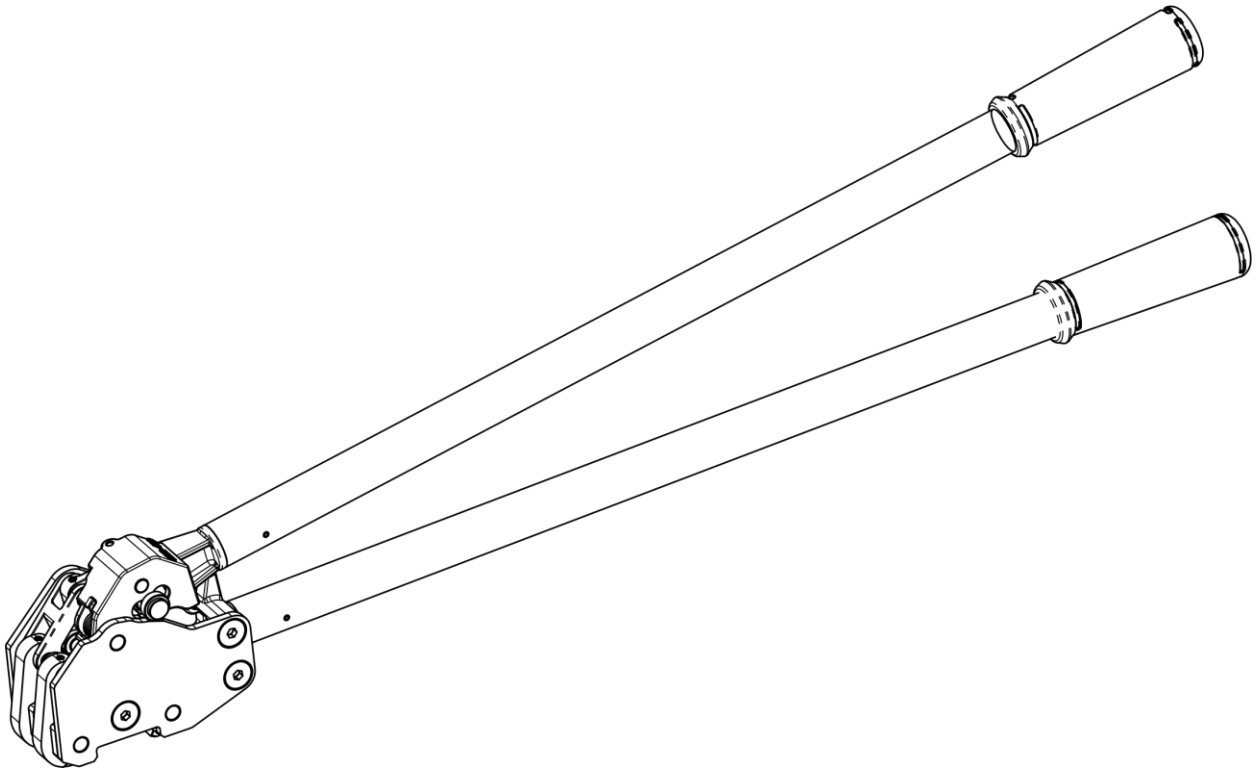

Strap Type	Regular Duty/High Tensile Steel
Strap Width	1 1/4" (32 mm)
Strap Thickness	Up to 0.044" (1.1 mm)
Joint Type	Seal
Weight	7.5 lbs (3.4 kg)
Handle Length	26.5"

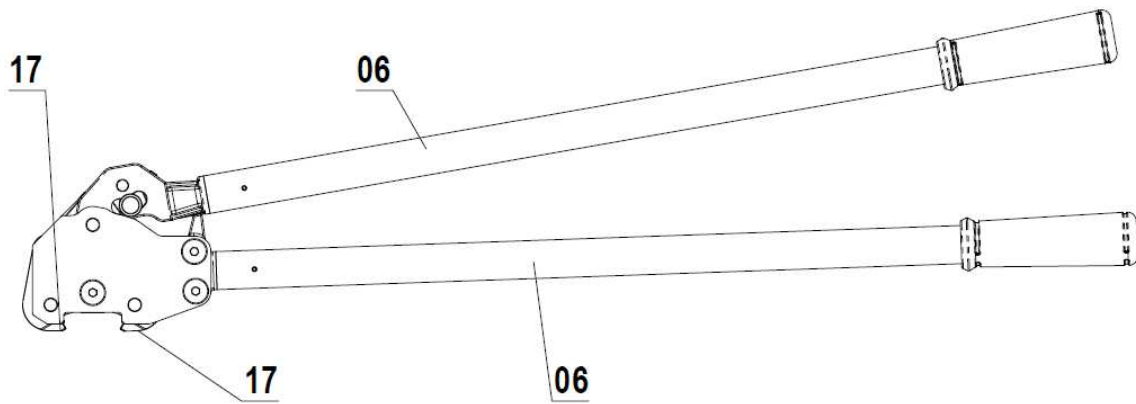

Fig. 1 – Starting Position

1. Place **Jaws 17** of the tool across the middle of the **Seal 102** as shown on Fig. 2

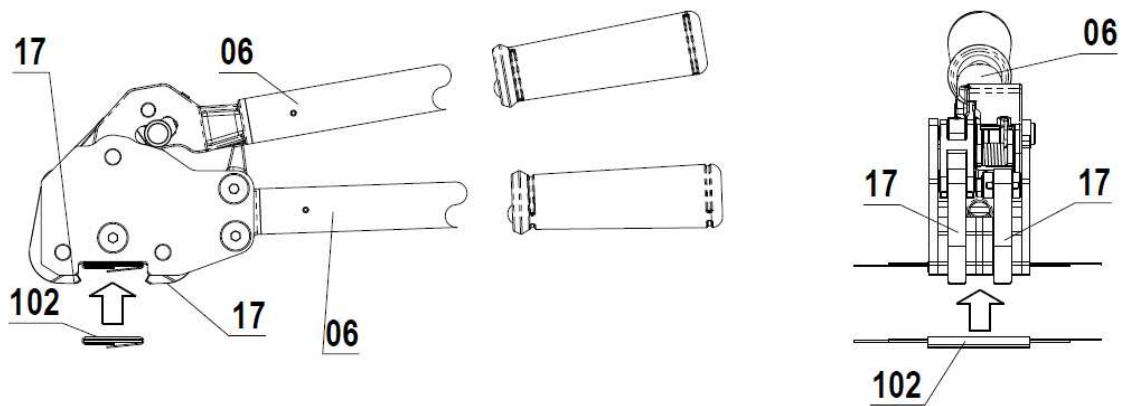

Fig. 2

2. Keeping **Jaws 17** on the middle of the seal move the **Upper Handle Lever 06** until you have a click as shown on Fig. 3. **Lower Handle Lever 06** remains at the same position.

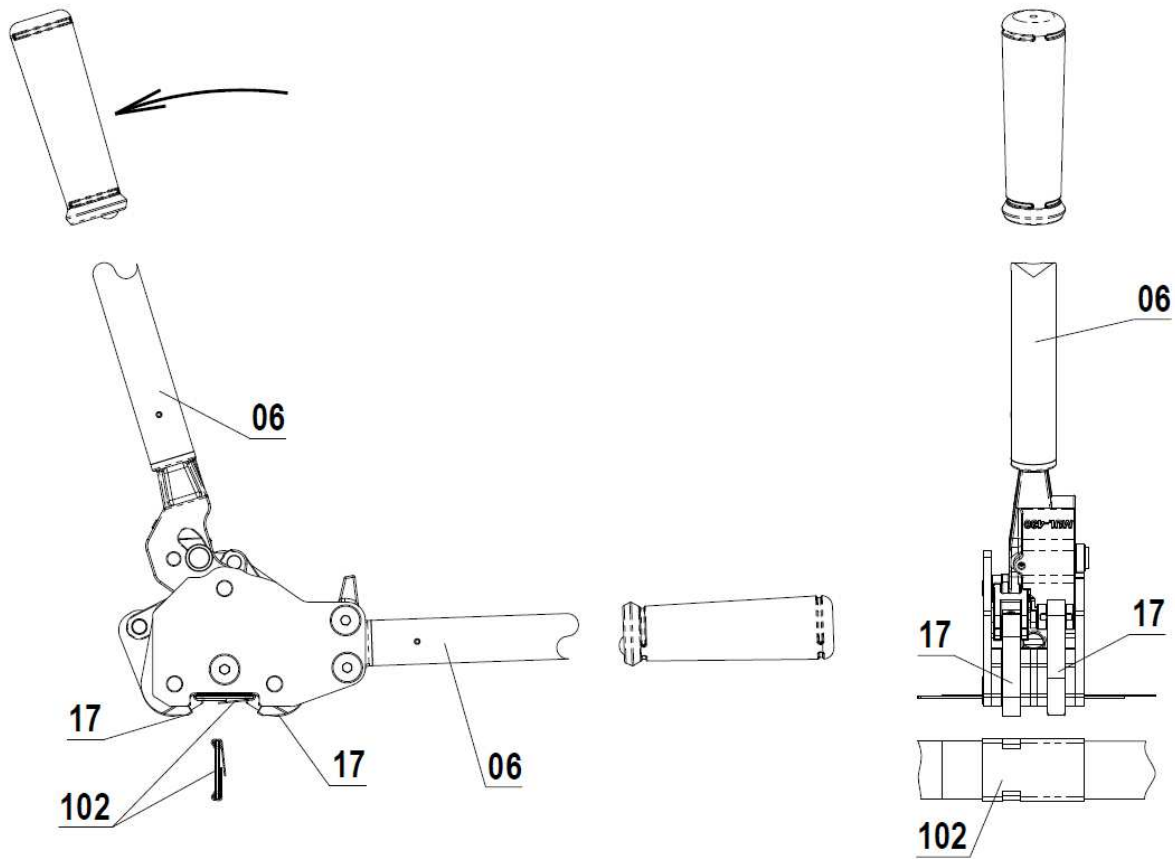

Fig. 3

3. Return the **Upper Handle Lever 06** to the starting position as shown on Fig.4

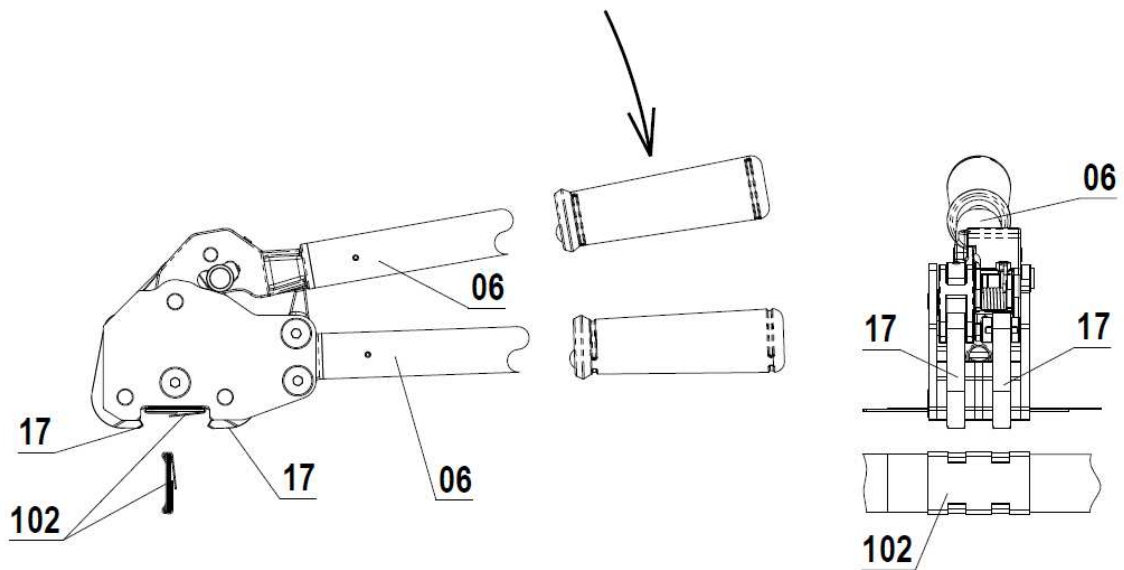

Fig. 4

4. Take the sealer off the seal. The operation cycle is now complete.